

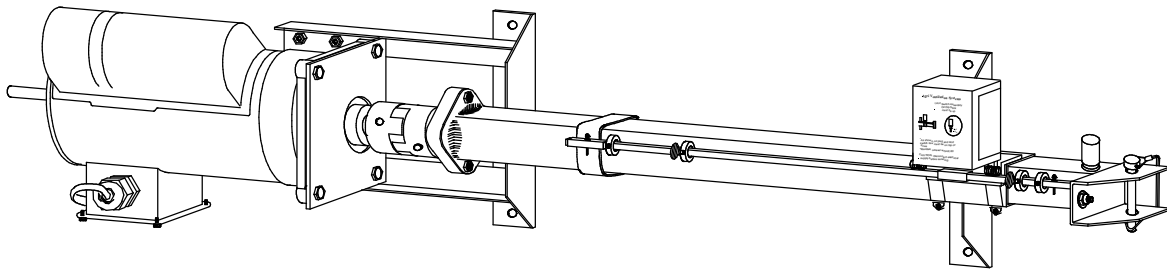

Simply Smart

CURTAIN AND INLET INLINE POWER DRIVE



INSTALLATION AND PARTS MANUAL

Read This Entire Manual Prior To Installation. This Manual Must Be Given To And Reviewed By The Grower After The Unit Has Been Installed. This Manual Should Be Kept In A Safe, Readily Accessible Place For Quick Reference.

Agri Ventilation Systems, LLC

Dayton, Virginia 22821

1-800-526-4188

INLINE POWER DRIVE MODELS

This installation Manual is designed for use with the Agri Ventilation Systems INLINE POWER DRIVE Units with the following Model Numbers:

<u>Model Number</u>	<u>Motor Rating</u>	<u>Rate of Travel</u>
DR-AN-xx02	115 VAC, 107 rpm	10.7 inches per minute
DR-AO-xx02	115 VAC, 40 rpm	4 inches per minute
DR-AP-xx02	115 VAC, 23 rpm	2.3 inches per minute
DR-DS-xx02	230 VAC, 107 rpm	10.7 inches per minute
DR-DR-xx02	230 VAC, 40 rpm	4 inches per minute

The designation 'xx' in the Model Number represents the length of the Drive Unit. These are as follows:

<u>xx</u>	<u>Length</u>	<u>Length of Travel</u>
18	18 inches	12 inches
30	3 feet	30 inches
40	4 feet	42 inches
50	5 feet	54 inches
60	6 feet	66 inches

MAINTENANCE RECOMMENDATION

The AVS Inline Power Drive uses an oil bath to lubricate its threaded rod. The Drive Unit is shipped dry from the factory. Oil must be added at installation; lack of oil in the drive unit will void the manufacturer's warranty. The illustration below shows a situation in which the oil level is high enough to cover the rotating rod.

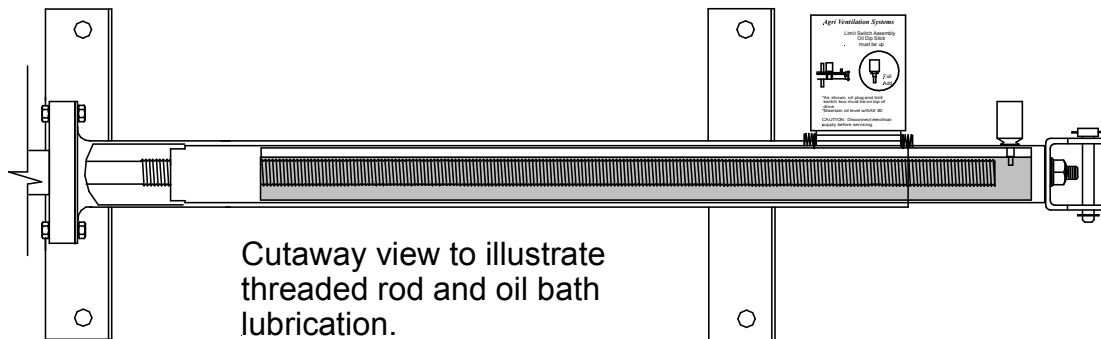

Fill the Drive with 80W90 Multipurpose Gear Oil when the unit is completely retracted. Run the Drive to the full extended position, retract and recheck the oil level. The Oil Level should be checked every 3 months; add oil as needed.

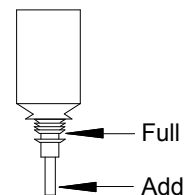

INSTALLATION RECOMMENDATIONS

The Inline Power Drive is designed to handle 2,000 pounds. The Installer must determine the weight of curtains or inlets and design accordingly.

The recommended mount is on an inside wall. This allows visual coordination of installation and service of the drive and power control unit. The drive unit may be mounted on a ceiling or outside wall. Outside units must be mounted under eaves and should be covered.

The Drive Unit is assembled at the factory for a right-hand extension of the inside drive. If necessary the limit switch rod and box assembly may be removed and reassembled to accommodate a left-hand extension of the inside drive.

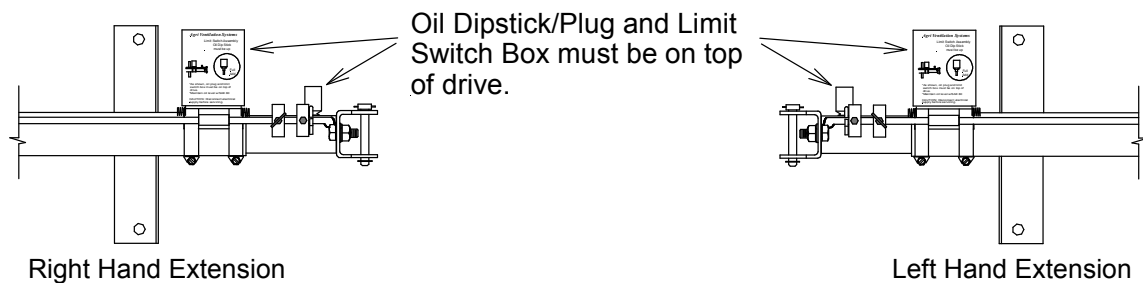

The Inline Power Drive unit is shipped completely retracted. Mount Drive Unit on a 2"x8" plank. Mount the unit so that the minimum distance to the first pulley is equal to the length of the drive unit plus one foot.

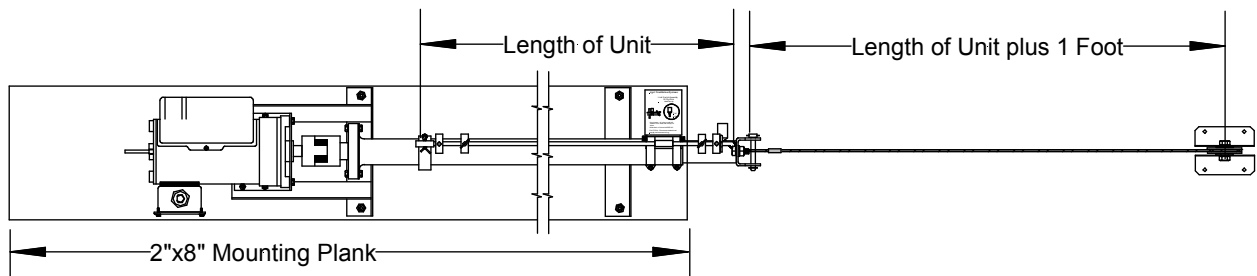

Mount Drive unit and pulley(s) to allow drive to pull in a straight inline direction.

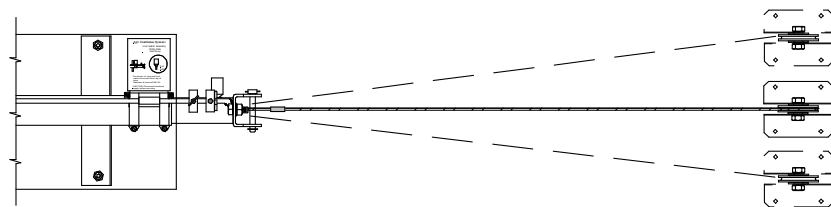

Dotted lines indicate incorrect cable alignment.

WALL MOUNT

Mount Inline Drive Unit on a 2"x8" board. The Drive Unit must be mounted as level as possible. The limit switch box and the oil dipstick must be on the upper side.

The working mechanism of the Drive Unit requires an oil bath for lubrication; all drive units must be mounted **horizontally** for lubrication purposes. At NO time should there be an out-of-level condition; the limit switch side of the drive must never be lower than the motor side.

The following figures are exaggerated for illustrative purposes:

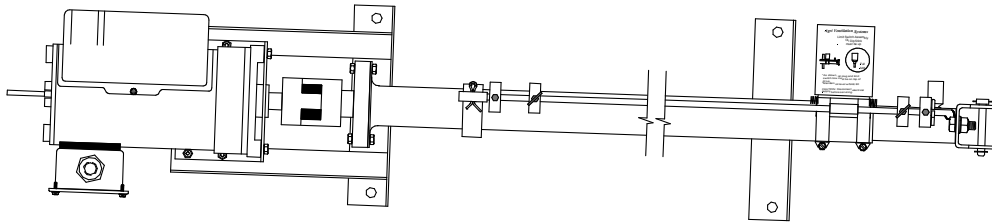

WRONG !!!

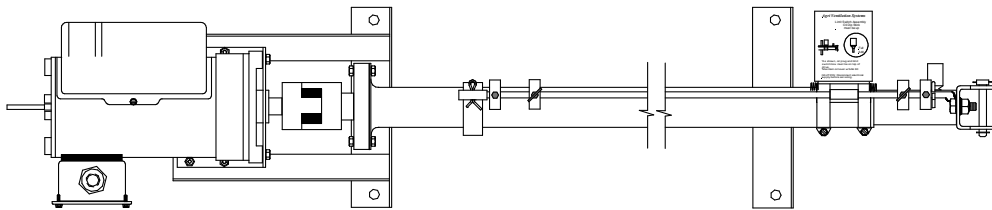

CORRECT

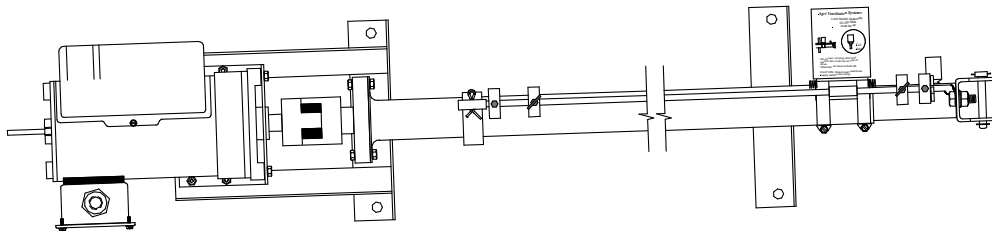

OKAY

The working screw is coated with **NEVER-SEEZ** during manufacture, but the unit is shipped dry. The Drive should never be operated without lubricant, otherwise failure or seizure will occur. Add oil to the Drive with the unit completely retracted during installation. Fill Drive completely **FULL** using **Multipurpose Gear Oil SAE 80W90**. After filling, test the unit and add oil if necessary.

Check the oil level and add oil with the Drive completely retracted. Check every three months and add oil as needed.

CEILING MOUNT

For ceiling mount installations of the Inline Power Drive, mount the motor end of the drive about ¼ inch lower than the limit switch end of the drive. This will ensure lubrication of the critical working zone of the Drive Unit.

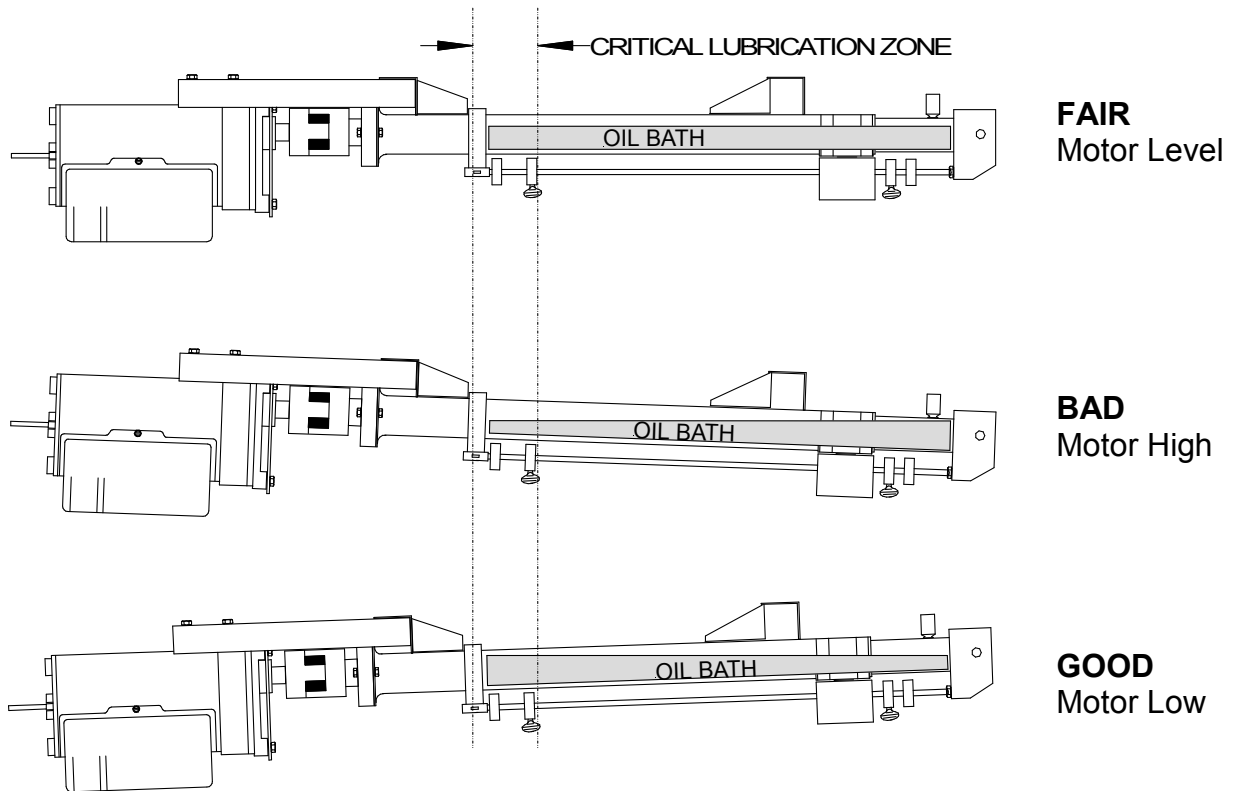

The Oil Dipstick must be on the upper surface of the drive. There is an allen screw oil plug on that surface to accommodate a ceiling mount installation. Remove the allen screw and place in the hole for the Dipstick. To provide increased room for Dipstick removal and oil filling, line up the end of the 2"x8" mounting plank with the end of the exterior tube on the drive unit as illustrated below:

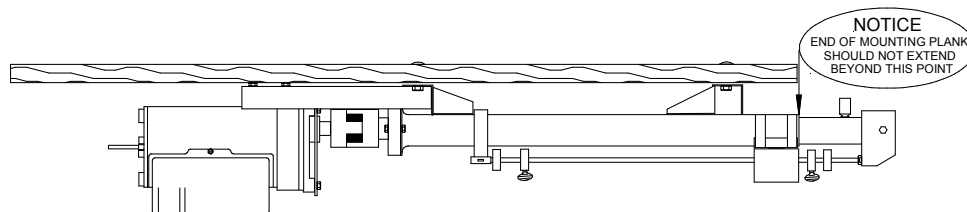

Fill the Drive with oil when the unit is fully closed or retracted. Run the Drive to fully extend the unit, then retract and check the oil again. Fill as needed. The oil level should reach the bottom threads of the Dipstick.

SAMPLE ILLUSTRATIONS FOR CABLE WINCHING

(These are for illustration only and are not to scale. For actual installation distances between the various components – Drive unit, pulleys, brackets, hand winch – must be sufficient to allow for full travel.)

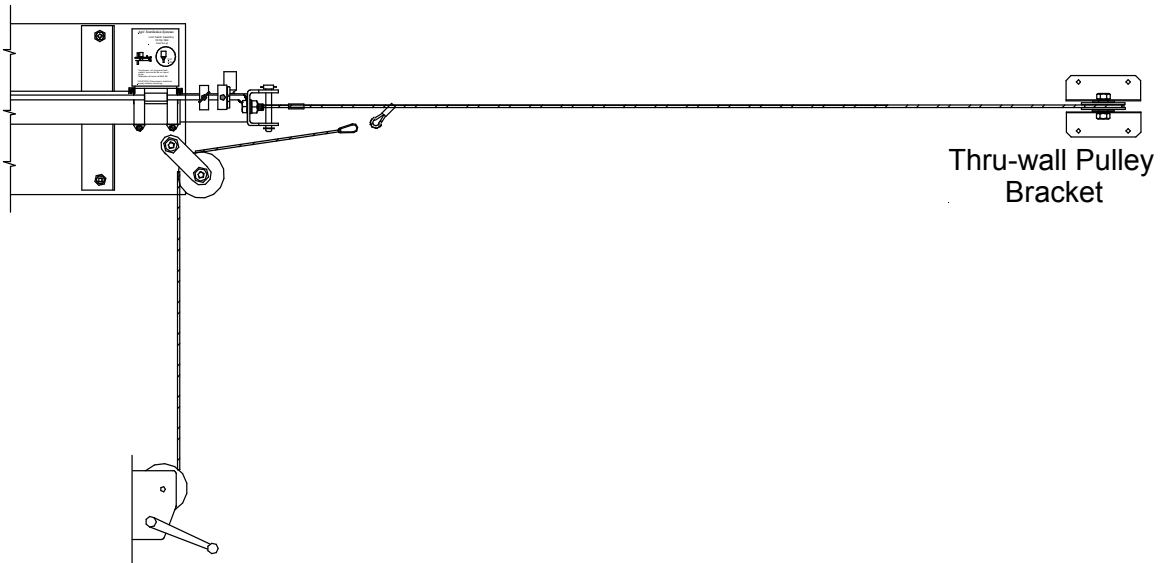

Inline Power Drive direct connection to cable, 1 to 1 ratio (1 foot of Drive travel yields 1 foot of cable travel), with quick release clip on hand winch.

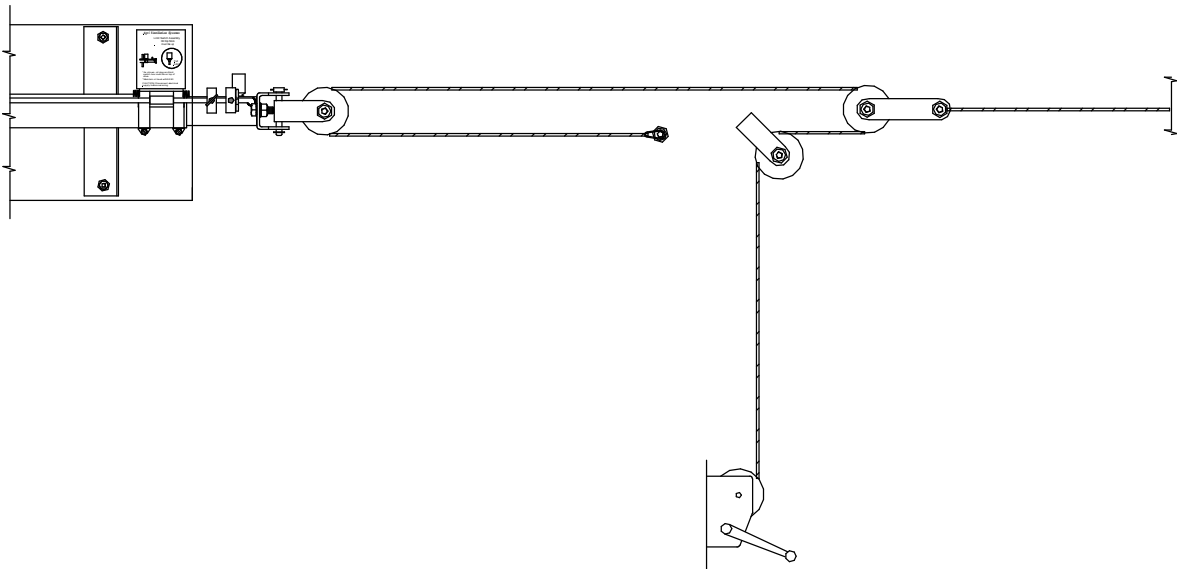

Inline Power Drive indirect to cable via pulleys, 1 to 1 ratio, with fixed hand winch readily available

SAMPLE ILLUSTRATIONS FOR CABLE WINCHING

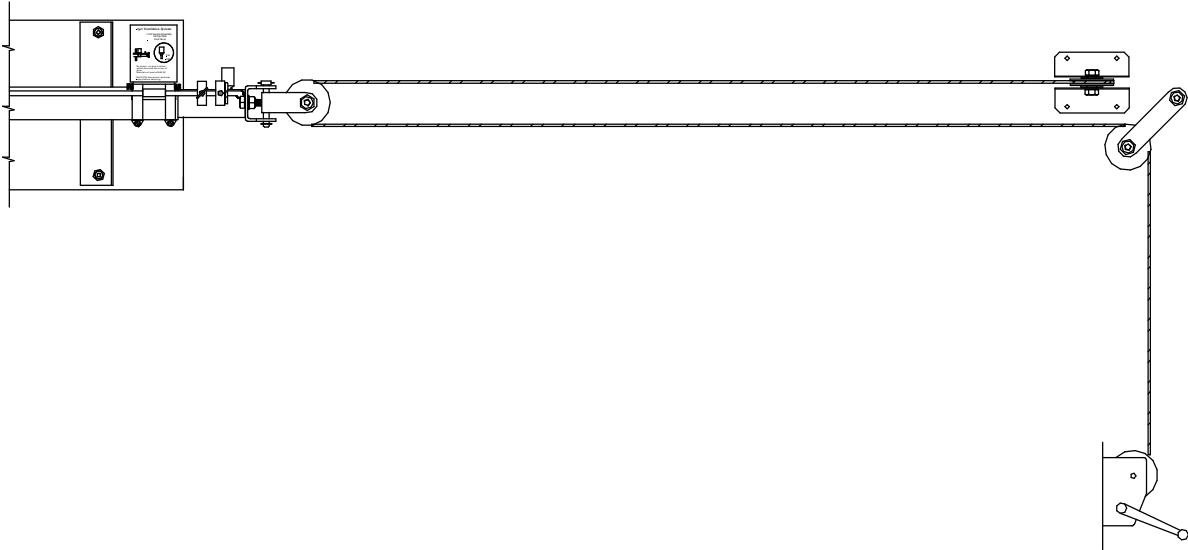

Inline Power Drive connection to cable, 1 to 2 ratio (1 foot of Drive travel yields 2 feet of cable travel), with readily available hand winch. The travel speed of the cable (with curtains or vent doors) is also twice that of the Drive.

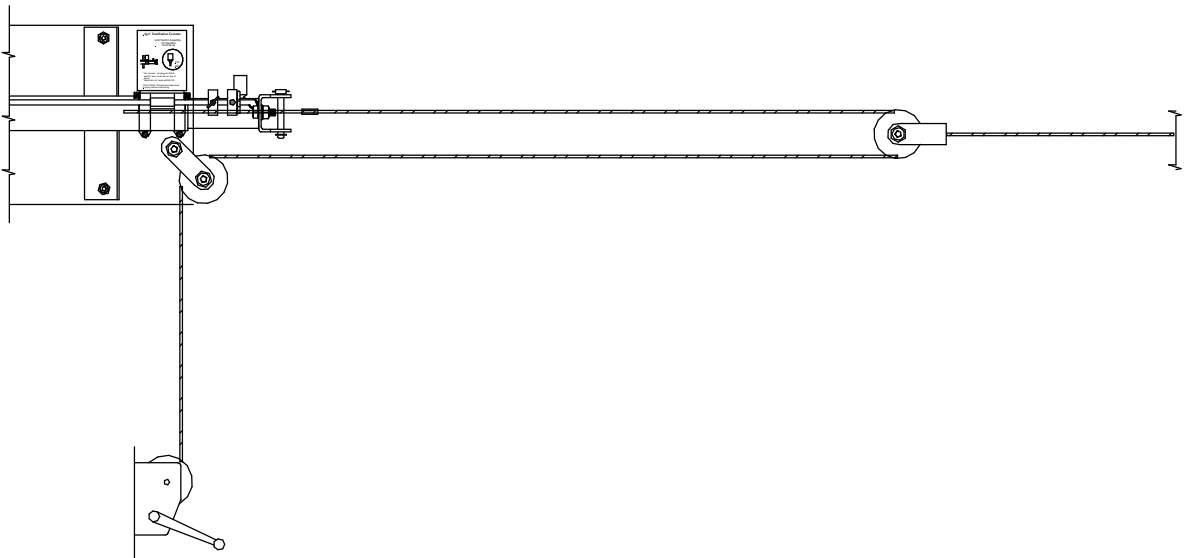

Inline Power Drive connection to cable via pulley, 2 to 1 ratio (2 feet of Drive travel yields 1 foot of cable travel), with readily available hand winch. The travel speed of the cable (with curtains or vent doors) is half that of the Drive.

INLINE POWER DRIVE PARTS LIST

Refer to the diagrams on the following pages.

<p>1. 115VAC Motor: 107 rpm: EP-FR-0107 40 rpm: EP-FR-0040</p> <p>1a. Capacitor Cover: EP-FR-1000</p> <p>1b. Junction Box & Cover: EP-FR-1001</p> <p>2. Motor Key:</p> <p>3. Motor Mount: EP-FR-MOUT</p> <p>4. Lovejoy, 5/8": DR-LJ-0058</p> <p>5. Urethane Lovejoy Spider: DR-LJ-000U</p> <p>6.</p> <p>7. 1/4" Nut: NT-.250</p> <p>8. Bolt, 1/4" x 1/2": BT-.250-.5G2</p> <p>9. 1" Watertight Connector: EP-CN-1213</p> <p>10.</p> <p>11.</p> <p>12. #122 1/4" Saddle: DR-SB-0122</p> <p>13. Cotter Pin: CP-.109-.5</p> <p>14. Set Collar, 3/8": HW-LC-1001</p> <p>15. Set Collar w/ Thumb Screw</p> <p>16. Thumb Screw: TS-.250-.5</p> <p>17. Limit Switch Rod:</p> <p>18 Inch: DR-SS-1825</p> <p>3 foot: DR-SS-3025</p> <p>4 foot: DR-SS-4025</p> <p>5 foot: DR-SS-5025</p> <p>6 foot: DR-SS-6025</p> <p>18. Limit Switch Assembly: DR-BX-1000</p> <p>19. Motor Wire:</p> <p>18 Inch: DR-MW-1800</p> <p>3 foot: DR-MW-3000</p> <p>4 foot: DR-MW-4000</p> <p>5 foot: DR-MW-5000</p> <p>6 foot: DR-MW-6000</p> <p>20. Limit Switch/Control Wire: DR-MW-1000</p> <p>21. Outside Drive:</p> <p>18 Inch: DR-OO-1800</p> <p>3 foot: DR-OO-3000</p> <p>4 foot: DR-OO-4000</p> <p>5 foot: DR-OO-5000</p> <p>6 foot: DR-OO-6000</p>	<p>22. Bolt, 1/4"x3/4": BT-.250-.75G</p> <p>23. Bolt, 1/4"x1": BT-.250-1G5</p> <p>24. 5/8" Bearing: DR-BR-F000</p> <p>25. 1/4" x 1 3/4" Tension Pin: TP-.250-1.75</p> <p>26. 5/8" Lovejoy w/ Tension Pin hole and Tension Pin: DR-LJ-000R</p> <p>27. 2" Hose Clamp (2): HW-HC-2000</p> <p>28. Oil Plug/Dipstick: HW-OP-1000</p> <p>29. Lynch Pin: HW-LP-0000</p> <p>30. Inside Drive:</p> <p>18 Inch: DR-OO-1801</p> <p>3 foot: DR-OO-3100</p> <p>4 foot: DR-OO-4100</p> <p>5 foot: DR-OO-5100</p> <p>6 foot: DR-OO-6100</p> <p>31. Pipe Plug: PP-.125</p> <p>32. 1/4" Flat Washer: WA-.250S</p> <p>33. 1/4" Lock Washer: LW-.250</p> <p>34.</p> <p>35. 1/4" Lock Nut: LN-.150E</p> <p>18. <u>Limit Switch Assembly:</u></p> <p>41. #100 Limit Switch Bracket: DR-SB-0100</p> <p>42. 4/40 Nut: NT-440</p> <p>43. 4/40x1" Machine Screw: MS-440-1PHP</p> <p>44. Minibox Back: EP-BX-1101</p> <p>45. Ground Wire w/ spade:</p> <p>46. Limit Switch, straight arm: EP-SW-M100</p> <p>47. Minibox Cover: EP-BX-1102</p> <p>48. Label: Oil Fill: PP-LB-OILF</p> <p>49. Limit Switch, curved arm: EP-SW-104G</p> <p>50. Limit Switch Spring: DR-OO-B110</p> <p>51. 4/40x1 1/4" Machine Screw: MS-440-1.25PHP</p> <p>52. 4/40x3/8" Machine Screw: MS-440-.375PHP</p> <p>53. Fail Safe Wire Jumper:</p> <p>54. Insulating Paper: PP-FH-1000</p>
---	--

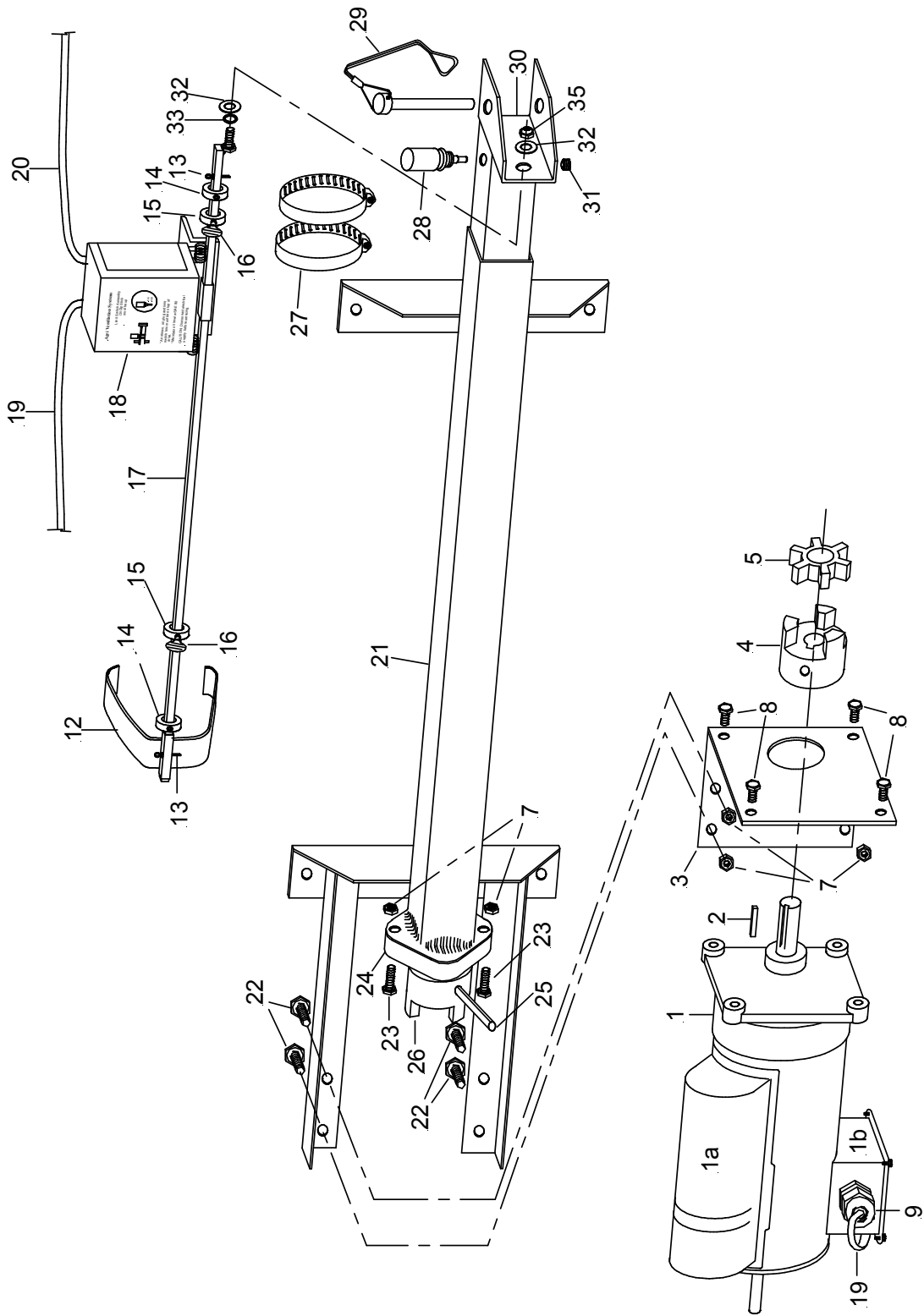

INLINE POWER DRIVE

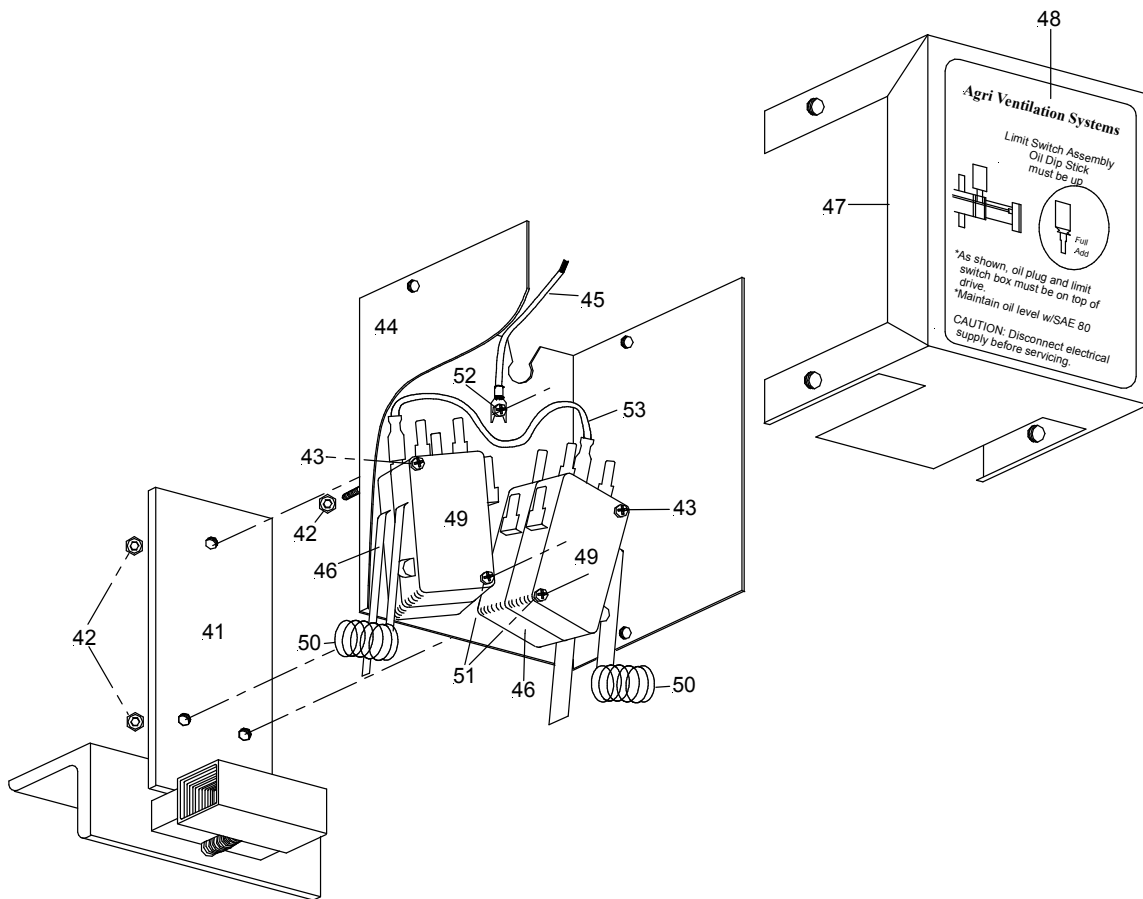

Limit Switch Box Assembly: DR-BX-1000

LIMITED WARRANTY

If it appears within one year from the date of invoice between the Purchaser and Agri Ventilation Systems, LLC, that any products or component parts do not conform to the specifications and physical descriptions given to the Purchaser, or that such products or component parts do not perform the function for which they were intended, the Purchaser, at their expense, shall return the products or component parts to the Seller, as prescribed in the AVS Return Materials Policy, with a RGA number, and a written report of defects or failed performance. The Seller shall review the report and inspect the items, and shall determine warranty status, and shall authorize, where applicable, either the repair or replacement of any non-conforming, or non-functioning product or component parts. The liability of the Seller to the Purchaser arising out of the supply of, or use of the product or component parts, whether such liability shall arise during the warranty period, shall in no case exceed the amount paid by the Seller in the repair or replacement of non-conforming, or non-functioning product or component parts. Upon the expiration of the warranty period, all liability of the Seller shall terminate.

Any warranty will be terminated if any product or component parts are installed improperly, misused, misapplied, tampered with, abused, modified, or altered without authorization from Agri Ventilation Systems, LLC. Warranty will not apply to defects of failures caused by, or due to Acts of God, or nature.

WARNING: WHEN THE PRODUCT OR COMPONENT PARTS ARE USED IN A LIFE SUPPORT VENTILATION SYSTEM, WHERE FAILURE COULD RESULT IN LOSS OR INJURY, THE USER SHALL PROVIDE ADEQUATE PERSONAL ATTENTION, BACK-UP VENTILATION, SUPPLEMENTARY NATURAL VENTILATION, OR FAILURE SYSTEMS, ETC., NECESSARY TO CONTROL THE OPERATION, OR ACKNOWLEDGE WILLINGNESS TO ACCEPT THE ASSOCIATED RISKS OF SUCH LOSS OR INJURY.

This equipment is offered for sale specifically on the Purchaser's acceptance of the above conditions and the manufacturer's warranty for this equipment. Acceptance, retention, installation, or operation of this equipment by the Purchaser shall be considered as acknowledgment and acceptance of the above conditions.

AGRI VENTILATION SYSTEMS, LLC
P. O. Box 40, Dayton, VA 22821